



DOCK LEVELLER

Product Catalogue

www.powertech.com.my

INTRO

DOCK LEVELLER, a hydraulic platform specifically designed for installation at loading docks within warehouses and distribution centers. Its primary function is to bridge the height differential between the dock and truck beds, enabling safe and efficient loading and unloading operations. The leveller's design accommodates various vehicle heights, enhancing work flow and reducing potential hazards.

By incorporating a dock leveller into loading operations, organizations can achieve several benefits: Operational Efficiency, Safety Enhancements, Reduced Equipment Damage and Lower Injury Risks.

Overall, the implementation of dock levellers contributes to optimized logistics operations and is crucial for maintaining safety standards in industrial environments.





20

21

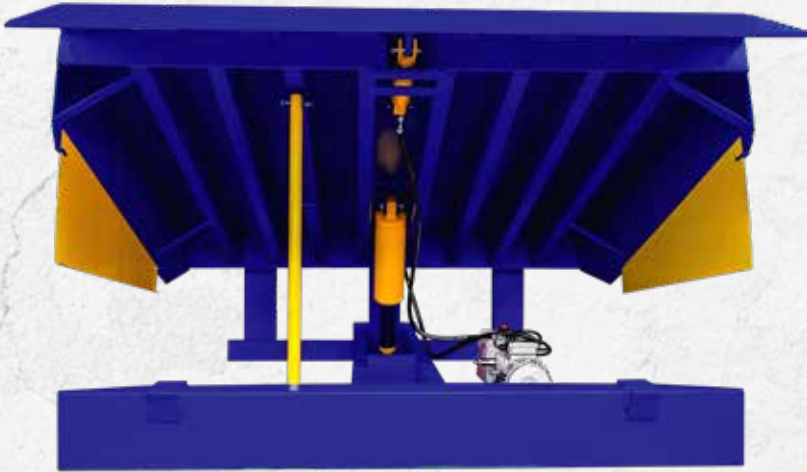

Structure

The mechanical platform is the physical structure that bridges the gap between the warehouse floor and truck bed, it included Deck, Lip, and hinge assembly.

The lip extends outward to rest on the truck bed, allowing smooth loading and unloading activities.



Hydraulic

The hydraulic System provides the lifting and lowering mechanism for the dock leveller. It consist of Hydraulic Pump, Electric Motor, Cylinder and hoses.

When activated, the hydraulic pump pressurises the hydraulic fluid, causing the cylinder extend, this movement raises or lowers the platform to match the truck bed height



Electrical

The Electrical System control the overall operation of the dock leveller, it includes component such as MCB, limit switch and control panels.

This electrical elements manage safety features, positioning, and auto return system





MAIN COMPONENTS

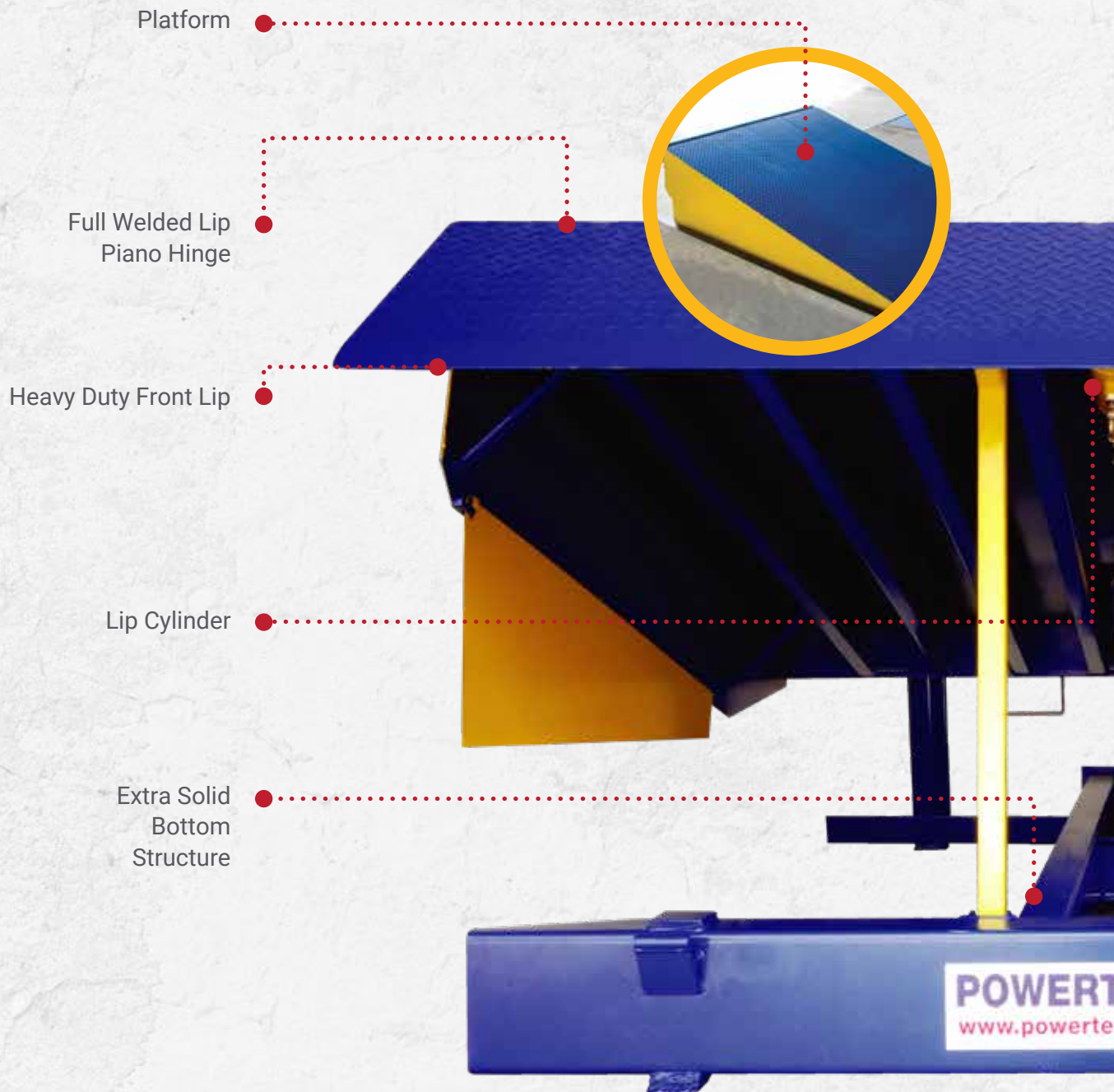

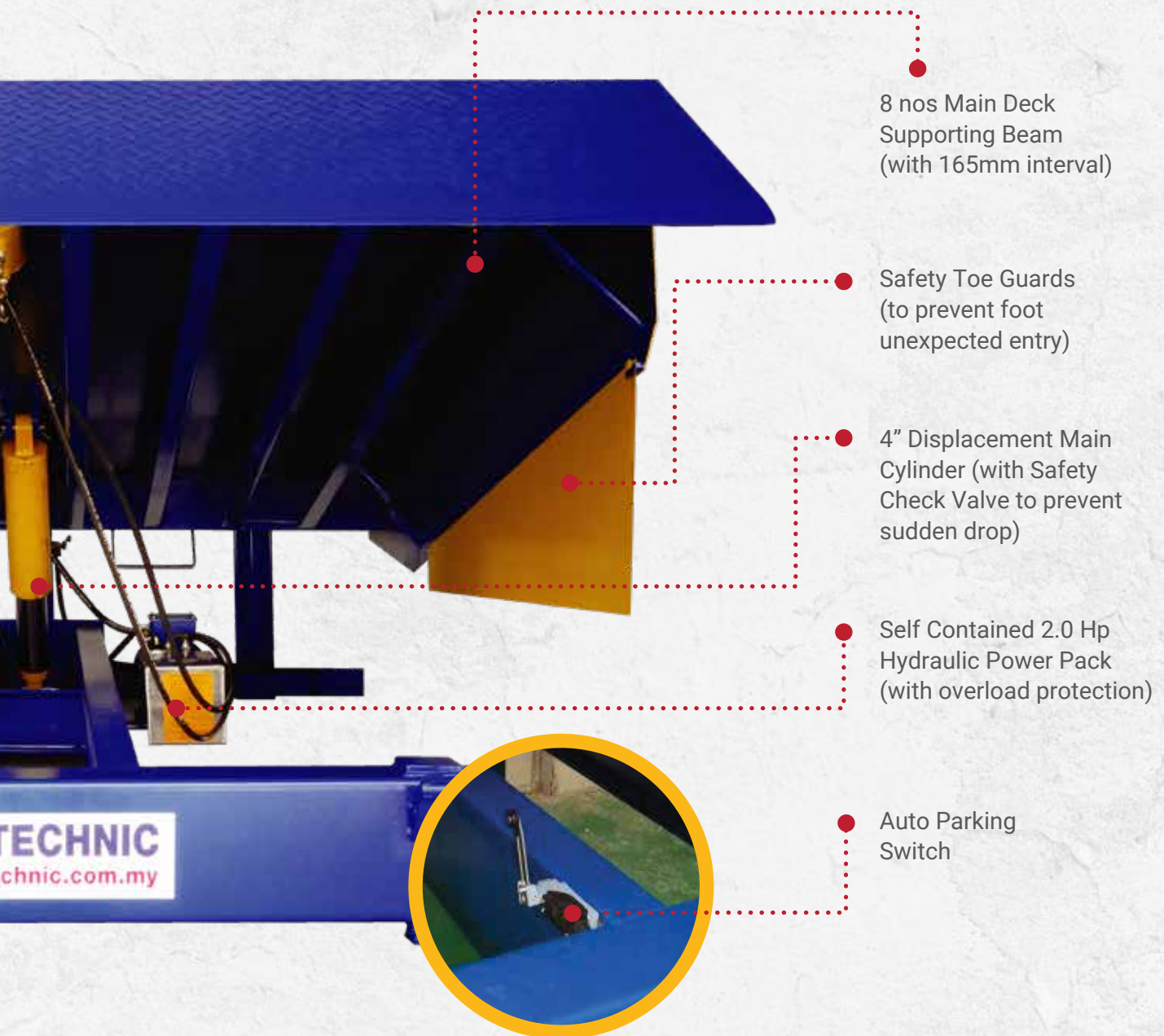

STRUCTURE



Heavy Duty Lips 50 mm

12mm thickness Lip on dock leveller serve a critical purpose in ensuring safe and efficient loading and unloading operation.

Digid Platform

150mm Gap Platform : Typically constructed with high tensile steel for durability and strength to withstand heavy load.

Solid Piano Hinge

Continuous hinges that run the full width of the dock leveller platform, connecting the platform to the lip, compared to traditional multi-point hinges, piano hinges require less maintenance and offer better alignment over time. It provides smooth movement when the lip deploys and retracts, minimizing friction and the chance of mechanical jamming.

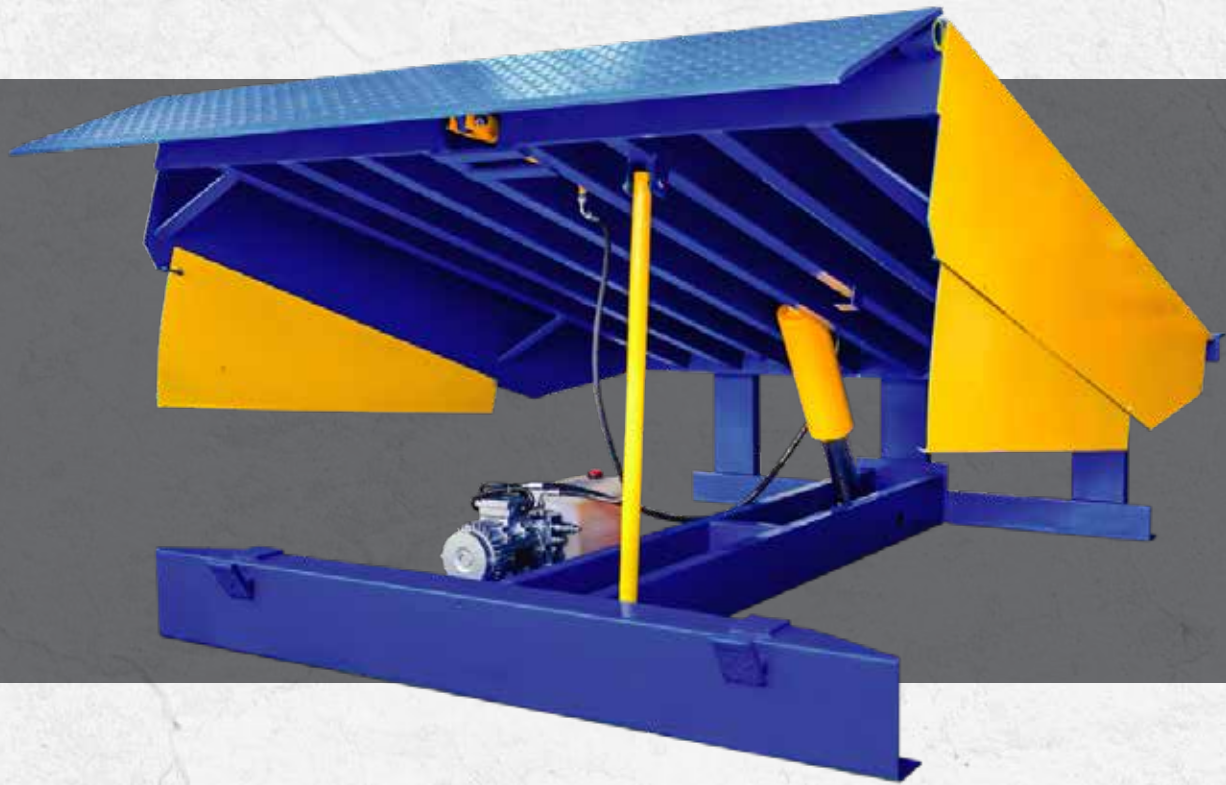

Sufficient Toe Guard

It is on the side of Dock Leveller to prevent worker's toes from getting caught underneath the deck during loading and unloading operation.

Digid Support Structure

Strong support frame provides stability and load-bearing capacity for the entire Dock Leveller, it ensures that the platform remains secure during loading end unloading activities.

Digid Base Beam

Main Base beam allow the cylinder to take the load when auto burst valve is activated.

Maintenance Bar

It is placed across the platform of the dock leveller, it prevents accidental lowering of the dock leveller while maintenance is in progress.

HYDRAULIC

Powerpack

2 HP Powerpack, ensure reliable performance and safety for dock leveller .

Low Operating Pressure

500psi Low-pressure system to ensure power pack long working life, also put less stress on seals, hose and others components

Pump Overload Protection

Safety feature designed to prevent damage to oil pumps by detecting and responding to conditions that could cause the motor or pump system to exceed its designed capacity. This feature is essential in Dock Leveller to ensure reliability, minimize downtime, and extend the life of the equipment.

Cylinder with Hose Burst Check Valve

100mm bore cylinder is engineered to maintain optimal operation at 500 psi, ensuring extended component life span and minimized maintenance costs. The cylinder is integrated with a hose burst check valve, a critical safety feature designed to hold the platform securely in place. This valve activates automatically if the truck prematurely departs from the dock leveller, preventing unintended movement of the platform and ensuring operational safety.

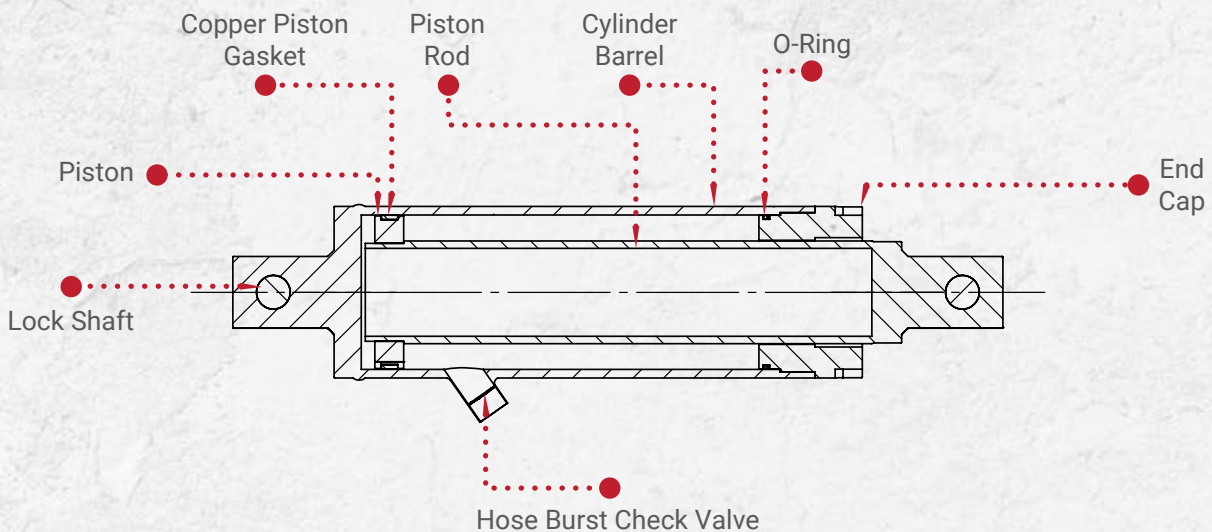

ELECTRICAL

Full Auto Operating System

The Powertechnic dock leveller is engineered with a fully automated operation system, allowing for seamless control via a single push button. This design facilitates the lifing of the platform and the extension of the lip with minimal user intervention, enhancing operational efficiency and user convenience.

Auto Return System

The Auto Return System designed to ensure that the dock leveller platform consistently returns to a neutral position after each use. This feature is critical for maintaining safety for both forklift operators and workers in the vicinity, by ensuring that the platform remains in a stable, neutral position, the system reduces the likelihood of accidents, thereby protecting personnel and equipment from potential hazards associated with unintentional movement.

Low Control Voltage

Designed with low operating voltage systems enhance safety and efficiency in industrial applications. Operating at lower voltages reduces the risk of electrical hazards and allows for safer operation in environments where moisture or other hazardous conditions may be present.



ACCESSORIES

Rubber Bumper

Rubber bumpers for dock levellers are essential components used to protect both loading docks and vehicles during the loading and unloading process, our rubber bumper covers larger areas, offering more comprehensive protection.



DOCK LEVELLER STANDARD SIZE

- Platform Size : 1830(W) x 2250(L) x 590(H) mm
- Pit Size Request : 1880(W) x 2260(L) x 610(H) mm
- Lip Length : 406 mm
- With Lip Extended : 2656 mm
- Static Capacity : 13,600 kgs
- Dynamic Capacity : 6,500 kgs
- Level of Balance : +300mm / -300mm
- Collapsed Height : 590 mm
- Main Deck Material : 6mm Mild Steel Chequered Plate
- Rubber Bumper : Inclusive 2 units as standard

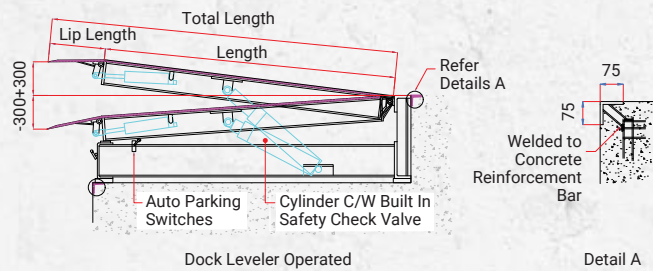
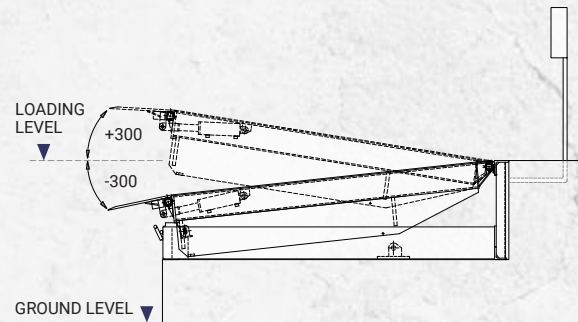

Dock Leveller Dimensions							Pit Dimensions		
Model	Capacity	Length	Width	Height	Lip Length	Total Length	Length	Width	Depth
DLP-590-2218	13.6	2250	1830	590	406	2656	2260	1880	610
DLP-590-2215	13.6	2250	1530	590	406	2656	2260	1580	610
DLP-590-2418	13.6	2400	1830	590	406	2806	2410	1880	610
DLP-590-2418	13.6	2400	1530	590	406	2806	2410	1580	610
DLP-490-2218	13.6	2250	1830	490	406	2656	2260	1880	510
DLP-490-2418	13.6	2400	1830	490	406	2806	2410	1880	510

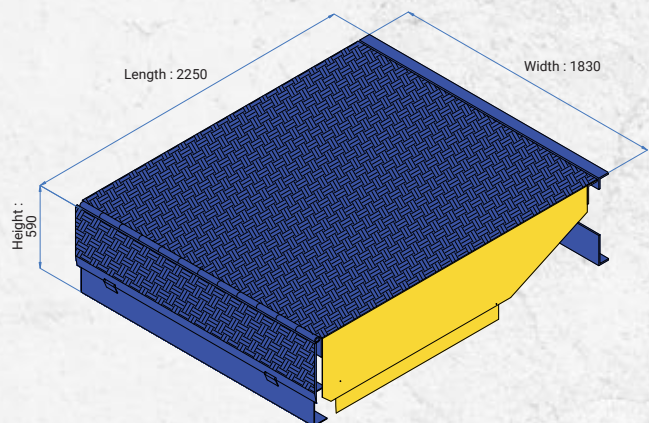
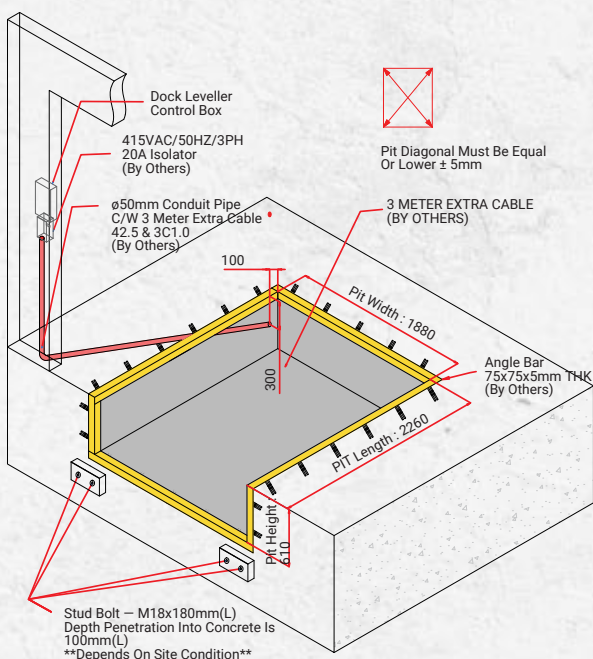



TELESCOPIC DOCK LEVELLER

A telescopic dock leveller is a type of adjustable platform used in loading docks to connect a warehouse floor with the bed of trucks. Unlike standard hinged-lip dock levellers, the telescopic version has an extendable lip that can be precisely positioned, offering more flexibility during loading and unloading operations.

This type of dock leveller frequently used for cold storage facility, minimize the open space between the vehicle and the dock to maintain consistent temperatures.

By installing a telescopic dock leveller, the sectional door can seal the entire entrance more effectively. This helps fully isolate indoor air conditioning and makes it harder for outside dust to enter.

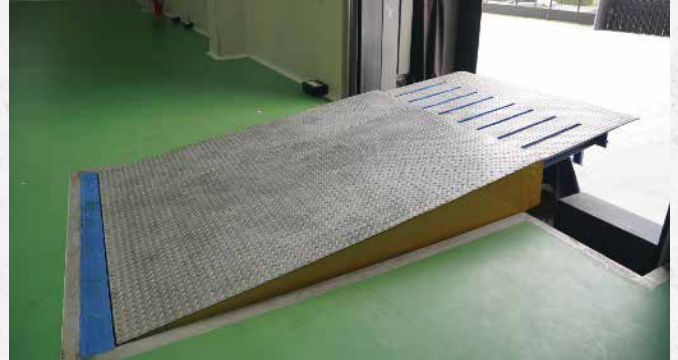

Dock Leveller Dimensions							Pit Dimensions		
Model	Capacity	Length	Width	Height	Lip Length	Total Length	Length	Width	Depth
DLTP-590-2520	13.6	2560	2000	590	1000	3560	2570	2050	610
DLTP-590-2518	13.6	2560	1830	590	1000	3560	2570	1880	610

